

47"
57"
60"

Let's rise to
the occasion.

the lift-your-spirits

Series L Adjustable Height Single Desk

ASSEMBLY INSTRUCTIONS

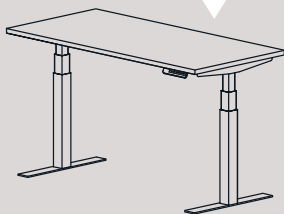

Included in the boxes:

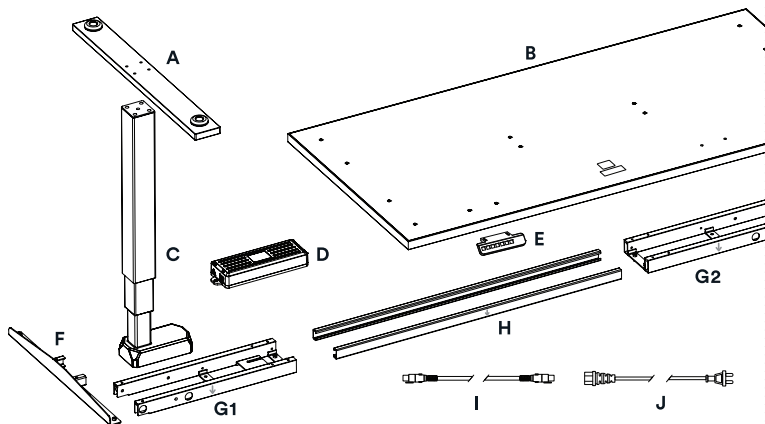

- A. Foot x2
- B. Desk Top x1
- C. Leg x2
- D. Control Box x1
- E. Control Handset x1
- F. Bracket x2

- G1. Leg Frame, Slotted x1
- G2. Leg Frame x1
- H. Spanning Rail x2
- I. Leg Jumper Cable x1
- J. Power Cable x1

Tools needed:

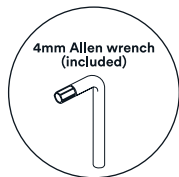

Screws included
(actual size):

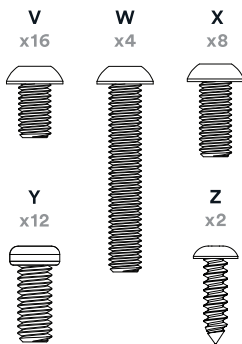

INSTRUCTIONS FOR ASSEMBLY

1. Lay the desk top on a blanket and set aside.

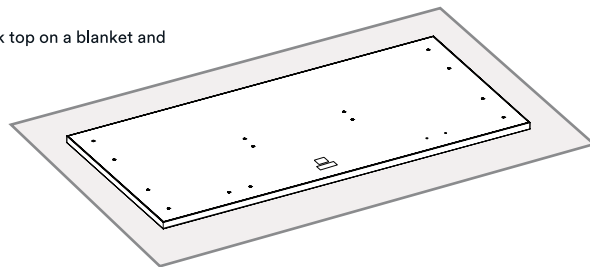

2. Lay out all leg structure parts. Be sure to disassemble the frame structure into two leg frames and two spanning rails. Set aside the control box.

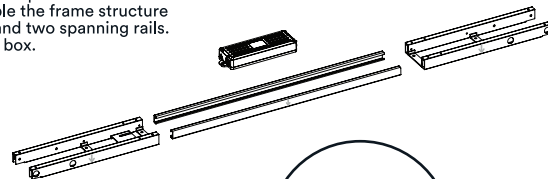

3. Align holes of leg frame G1 with either leg and attach all four screws.

Ensure the proper orientation of leg frame G1 as illustrated.

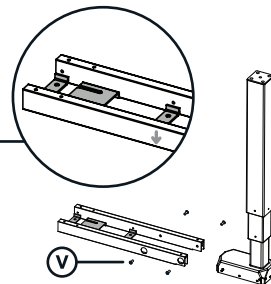

4. Slide the bracket onto leg frame section and attach both screws.

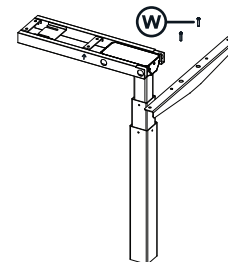

5. Attach foot to leg.

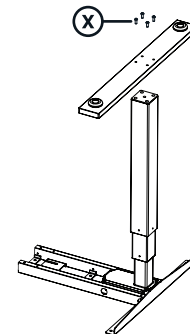

6. Repeat Steps 3, 4, and 5 using leg frame G2, leg, and bracket.

7. Slot the Spanning Rails between the opposing Leg Frame sections.

Ensure the Spanning Rails are oriented as directed by the arrow: outward and pointed toward the floor.

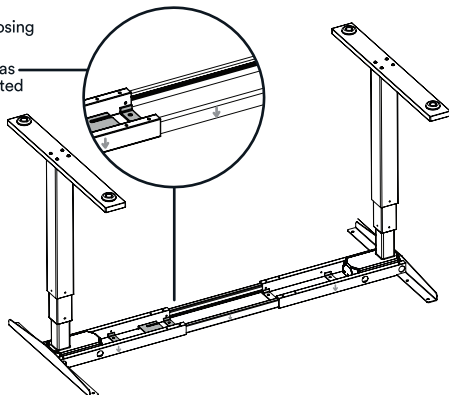

8. With a buddy's help, transfer entire leg frame structure to the desk top.

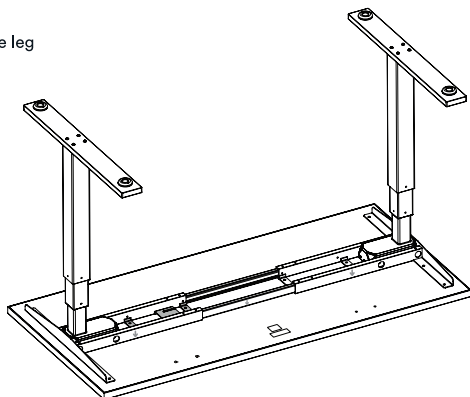

- 9a. Beginning at one end, align the bracket holes and leg frame holes with the pre-drilled holes on the desk top. Install 6 screws per leg.

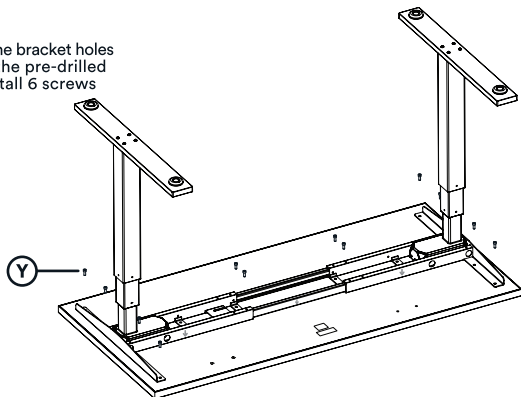

- 9b. Move to the opposing leg structure. Align and screw loosely to the desk top.

10. Shift the rail position as necessary to center the arrows.

Insert and tighten screws, pinning the spanning rails against the leg frame.

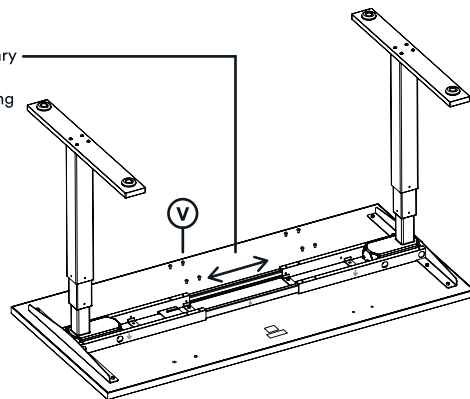

11. Slot the control box into leg frame G1.

Attach control handset, using the pre-drilled holes for guidance.

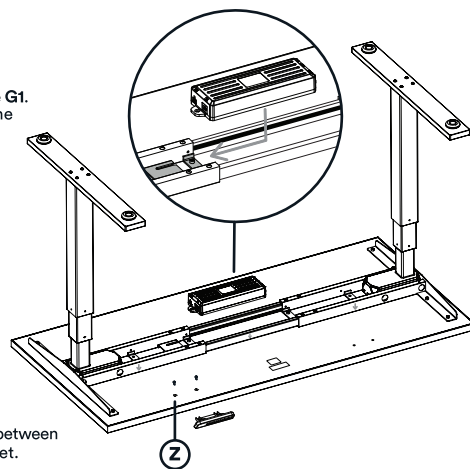

12. Complete the cable connections between the control box, legs, and handset.

Use cable I to complete the connection between the control box and the distant leg.



The handset cable plugs into the control box port marked "HS."

13. With your buddy, lift by the legs and rotate the desk upright. Move it to its intended spot and adjust the leveling glides, assuring that the desk surface is level (use the Level app on your smartphone).

14. Connect the power cord J to the control box and plug into the outlet. The LED display will light up.

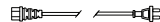

15. Follow instructions to reset the control box and further customize desk settings.

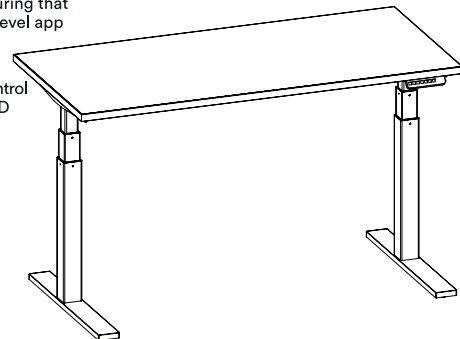

the lift-your-spirits

Series L Adjustable Height 72" Single Desk or Table

ASSEMBLY INSTRUCTIONS

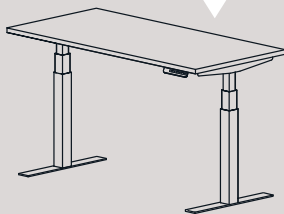

Included in the boxes:

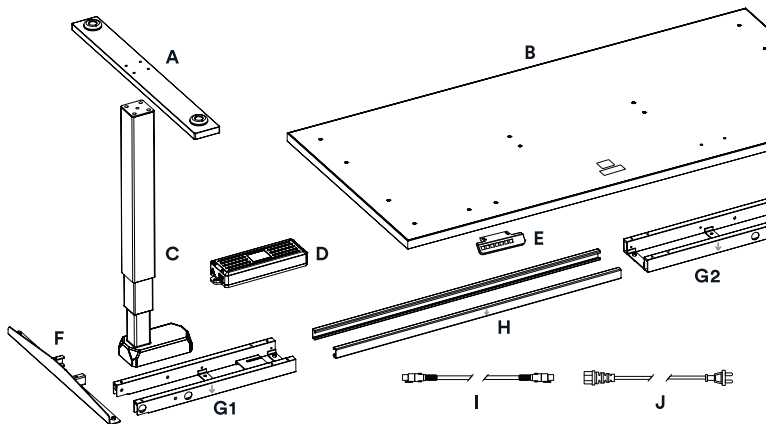

- A. Foot x2
- B. Desk Top x1
- C. Leg x2
- D. Control Box x1
- E. Control Handset x1
- F. Bracket x2

- G1. Leg Frame, Slotted x1
- G2. Leg Frame x1
- H. Spanning Rail x2
- I. Leg Jumper Cable x1
- J. Power Cable x1

Tools needed:



Screws included (actual size):

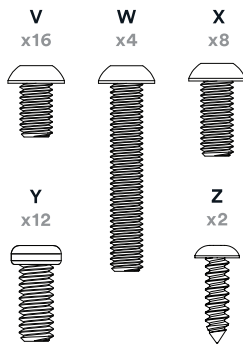

INSTRUCTIONS FOR ASSEMBLY

1. Lay the desk top on a blanket and set aside.

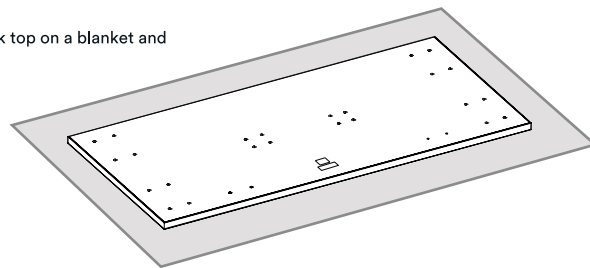

2. Lay out all leg structure parts. Be sure to disassemble the frame structure into two leg frames and two spanning rails. Set aside the control box.

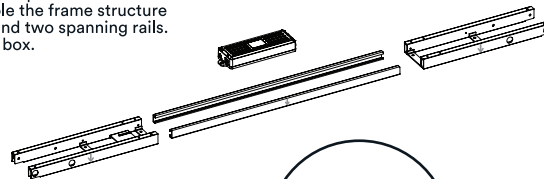

3. Align holes of leg frame G1 with either leg and attach all four screws. Ensure the proper orientation of leg frame G1 as illustrated.

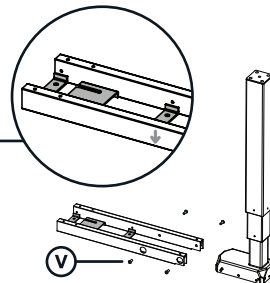

4. Slide the bracket onto leg frame section and attach both screws.

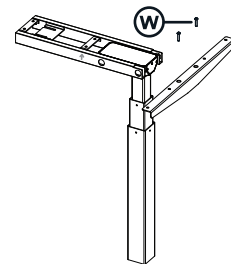

5. Attach foot to leg.

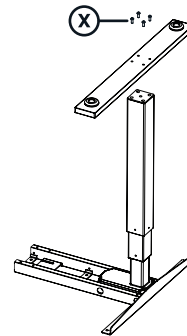

6. Repeat Steps 3, 4, and 5 using leg frame G2, leg, and bracket.

7. Slot the Spanning Rails between the opposing Leg Frame sections.

Ensure the Spanning Rails are oriented as directed by the arrow: outward and pointed toward the floor.

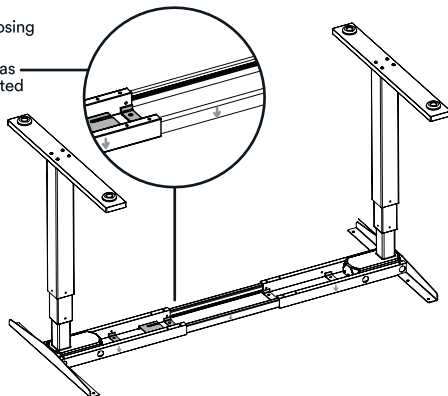

8. With a buddy's help, transfer entire leg frame structure to the desk top.

HEADS UP!

Choose your preferred alignment:
1. Desk assembly
2. Table assembly

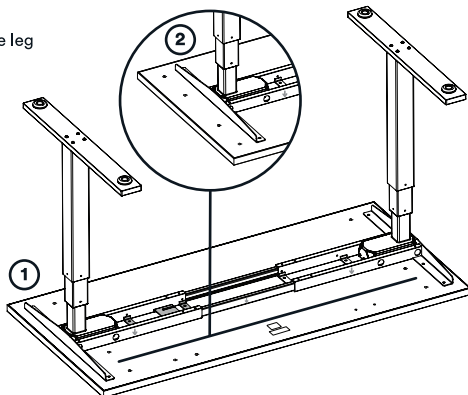

- 9a. Beginning at one end, align the bracket holes and leg frame holes with the pre-drilled holes on the desk top. Install 6 screws per leg.

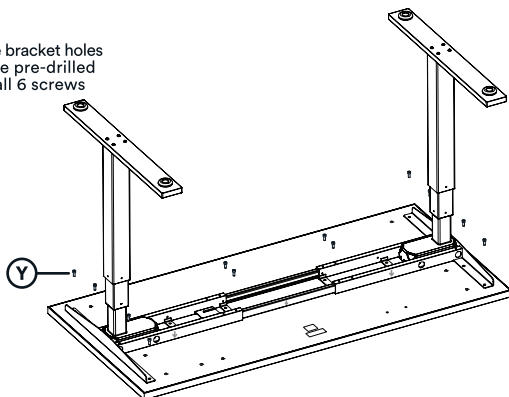

- 9b. Move to the opposing leg structure. Align and screw loosely to the desk top.

10. Shift the rail position as necessary to center the arrows.

Insert and tighten screws, pinning the spanning rails against the leg frame.

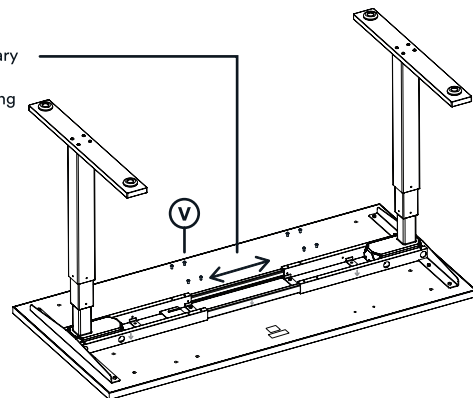

11. Slot the control box into leg frame G1.

Attach control handset, using the pre-drilled holes for guidance.

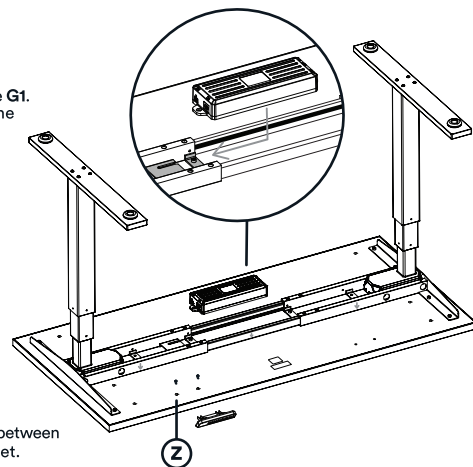

12. Complete the cable connections between the control box, legs, and handset.

Use cable I to complete the connection between the control box and the distant leg.

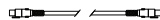

The handset cable plugs into the control box port marked "HS."

13. With your buddy, lift by the legs and rotate the desk upright. Move it to its intended spot and adjust the leveling glides, assuring that the desk surface is level (use the Level app on your smartphone).

14. Connect the power cord J to the control box and plug into the outlet. The LED display will light up.

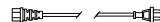

15. Follow instructions to reset the control box and further customize desk settings.

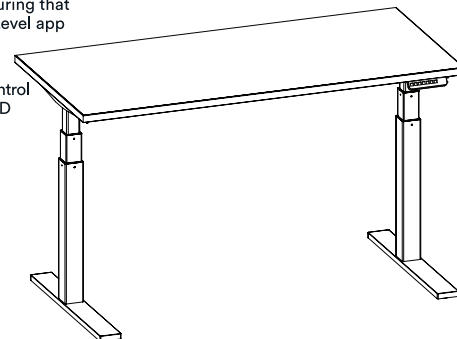

INSTRUCTIONS FOR USE

Take precautions

Failure to follow these recommendations could result in substandard product performance, property damage, and/or personal injury.

- Be aware of pinch hazards between the desk top edges and other objects.
- Keep objects out of the desk top's travel path: above, beside and under the desk, including your knees!
- Ensure the desk top remains at least 2" away from walls throughout the entire travel distance.
- Ensure all corded items used on the desk top have the cable length required to travel the entire range of motion.
- If the desk encounters resistance in its path, either up or down, it will rebound slightly and stop.
- Do not allow children to operate the desk unsupervised.
- Do not sit or stand on the desk top.
- Do not open the control box or the leg motor caps. Doing so voids the manufacturer's warranty and risks irreparable damage to the electronics and motor functions.
- The control box and motors have an operation cycle limit of 2 minutes on/18 minutes off. Use outside these norms can result in irreparable damage.
- This desk is meant for use in general office environments. All other use is at the user's own risk.
- Do not attempt to relocate the desk yourself. Grab a buddy for help!

Reset the control box

The Control Box must be reset prior to use, after power failures, or other mechanical errors.

1. Remove all objects from under the desk.
2. Press and hold the **DOWN** arrow key until the desk reaches its lowest point (about 24.5").
3. Press and hold the **DOWN** arrow key again for 5-10 seconds; release when the LED display reads **RST**.
4. Press and hold the **DOWN** arrow key one last time; the desk will lower and rise slightly. Release the key.
5. The LED display will then revert to displaying the actual desk height. That signals that the factory settings have been restored.

Calibrate the led display

Use the **DOWN** arrow key to move the desk to its lowest height. Measure the distance from the floor to the top of the desk. If the LED readout and the measured height match, skip the section below.

If the readout and measured height vary, follow these steps to adjust the readout.

1. While the desk is at its lowest height, press and hold the **DOWN** arrow key until the LED display reads **RST**.
2. Press and hold the **M** key until the LED display reads the current height again.
3. Use the **UP** and **DOWN** arrow keys to adjust the readout by 0.1 increments.
 - a. Use the **1** and **2** keys to change the readout by 1.0 increments.
 - b. Use the **3** and **4** keys to change the readout by 10.0 increments.
4. After reaching an accurate height readout, wait about five seconds; the LED display will return to **RST**.
5. Press and hold the **DOWN** arrow key; the desk will lower and rise slightly. Release the key.

The readout should now correspond to the measured height. Note that the lift mechanism has a ± 0.1 tolerance.

Perform basic functions

Press and hold the **UP** and **DOWN** arrow keys to raise and lower the desk top to the desired height.

Lock the Control Handset

Prevent unsupervised use by children.

1. Press the **M** button for 5 seconds, until the LED display reads **LCK**.
2. To unlock the Handset, press the **M** button for 5 seconds, until the LED display shows the desk height.

CAUTION: If the Control Box power supply is interrupted, then the handset will default to the unlocked mode.

Program the memory keys

Use memory keys to move to a pre-set height.

1. Use the **UP** and **DOWN** keys to move the desk top to the desired height.
2. Press the **M** key and then any of the four memory keys.
3. The height setting is now programmed.

Program key response preference

The Control Box includes two key response programs:

1. **One-Touch** response: memory keys are pressed briefly and the desk top travels to the pre-programmed height.
2. **Constant-Touch** response: memory keys are pressed constantly while the desk top travels to the pre-programmed height.
 1. Press and hold the **DOWN** arrow key until the desk reaches its lowest point.
 2. Press and hold the **DOWN** arrow key again, until the LED display reads **RST**.
 3. Press the 1 key to toggle between **10.1** or **10.2** programs. Release the 1 key and the display will readout **RST**.
 4. Press and hold the **DOWN** arrow key again, while the desk lowers and rises slightly. Release the key. The display readout will revert to the desk height.
 5. Press a memory key to test the selected preference.

Restrict the range of motion

The default factory settings allow the desk top to rise to 50" high and to lower to 24.5" high. If the user alters those limits, then the factory default settings must be restored in order to reach heights outside the user-programmed range.

Set the upper limit:

Be sure to consider the added clearance required after monitors are installed on desktops.

1. Use the **UP** arrow key to move the desk to the highest desired position.
2. Press the **M** key. The LED display will read **5-0**.
3. Press the **UP** arrow and the LED display will read **59.9**, indicating the highest height setting is programmed.

Set the lower limit:

This feature is particularly important when objects, like a file cabinet, are kept under the desk.

1. Use the **DOWN** arrow key to move the desk to the lowest desired position.
2. Press the **M** key. The LED display will read **5-0**.
3. Press the **DOWN** arrow key and the LED display will read **00.0**, indicating the lowest height setting is programmed.

Restore factory default settings for upper and lower heights:

1. Press the **M** key. The LED display will read **5-0**.
2. Press the **M** key and hold until the LED display reads **59.9**.
3. The LED display will then revert to displaying the actual desk height. This signals that the height restrictions have been removed.

Troubleshoot a problem

- If your control handset does not light up, check all the cable connection points between it, the Series L Desk control box, and the ultimate power source. Ensure all cables are securely connected. If you are using a power strip, ensure that the breaker switch is set to ON.
- If there is no power to your control handset, contact your office administrator or Poppin's customer support team.
- The first step toward solving most problems requires resetting the control box by following the instructions referenced earlier.
- If the LED display reads **50.1** or **50.2**, then check the cable connection points between the control box and each leg, ensuring the cables are plugged in, then reset the control box.
- If the LED display reads **18.0**, then discontinue use for approximately 20 minutes while the motors cool.
- If problems persist after resetting the control box twice, contact a Poppin sales representative or write to hi@poppin.com to discuss next steps.